

# PERFORMANCE IMPROVEMENT OF THREE PHASE INDUCTION MACHINE FED BY INDIRECT MATRIX CONVERTER USING PREDICTIVE CURRENT CONTROL

**Mr. M. Bharanitharan**

*PG Scholar,*

*Electrical and Electronics Engineering,  
K.S. Rangasamy College of Technology,  
Namakkal, Tamil Nadu, India*

**Ms. R. Radhamani**

*Assistant Professor,*

*Electrical and Electronics Engineering,  
K.S. Rangasamy College of Technology,  
Namakkal, Tamil Nadu, India*

**Abstract**— A new strategy for indirect matrix converters which allows an optimal control of source and load currents of induction motor is presented. The commutation state of the converter in the subsequent sampling time according to an optimization algorithm given by a simple cost functional and the discrete system model. The control goals are regulation of output current according to an arbitrary reference and also a good tracking of the source current to its reference which is imposed to have a sinusoidal waveform with low distortion. The indirect matrix converter fed induction motor model is simulated in Matlab/Simulink platform and the results are analyzed

**Keywords**— AC-AC Power Conversion, Current Control, Matrix Converter, Predictive Control.

## I. INTRODUCTION

The indirect matrix converter (IMC) [1] has been the subject to investigation for some time. One of the favorable features of an IMC is the absence of a dc-link capacitor, which allows for the construction of compact converters capable of operating at adverse atmospheric conditions such as extreme temperatures and pressures. These features have been explored extensively and are the main reasons why the matrix converters family has been investigated for decades [2]. IMC features an easy to implement and more secure commutation technique, the dc-link zero current commutation [3]. Moreover, the conventional IMC has bidirectional power flow capabilities and can be designed to have small sized reactive elements in its input filter.

These characteristics make the IMC a suitable technology for high-efficiency converters for specific applications such as military, aerospace, wind turbine generator system, external elevators for building construction and skin pass mill, as reported in [4]–[6], where these advantages make up for the additional cost of an IMC compared to conventional converters.

IMC uses complex pulse width modulation (PWM) and space vector modulation (SVM) schemes to achieve the goal of unity power factor and sinusoidal output current [2], [7]–[13].

Thanks to technological advances, fast and powerful microprocessors are used for the control and modulation of power converters. To deal with the high processing power needed for these microprocessors, some research has shown the positive potential of model predictive control (MPC) techniques in many power electronics applications [14], [15]. This is a nonlinear control method that takes advantage of the discrete inherent nature of the commutated power converter.

While there are a few challenges to the predictive control method, it has been demonstrated as an appealing alternative to power converter control because its concepts are very intuitive and easy to understand, and it can be applied to a wide variety of systems. In addition, it may involve multiple systems, dead time compensation, and nonlinear constraints, making it an easy controller to implement, particularly since it is open to modifications and extensions for specific applications, as reviewed in [16]–[21]. This control scheme has some advantages over traditional linear controllers and PWM modulators, such as fast dynamic responses and an easy inclusion of constraints on the system [22].

Predictive current control (PCC) can be described as a particular case of MPC which takes into account the inherent discrete nature of the switching states of the power converter and the digital implementation [20], [21], [23]–[25]. Most of PCC methods applied in matrix converters take into consideration the output current regulation and the instantaneous reactive power minimization on the input side, obtaining input currents in phase with their respective phase voltages. However, this cannot ensure that they present a sinusoidal waveform, particularly when harmonic distortion is present in the source voltage.

To overcome this issue and enhance the quality of the source current, in the following pages, this paper illustrates how the PCC can be applied to an IMC and how both source and load currents waveforms can be directly controlled.

## II. INDIRECT MATRIX CONVERTER

Indirect Matrix converters are AC to AC power converter topology that can generate required amplitude and frequency AC sinusoidal wave form conventional AC source based mainly on semiconductor switches with minimal requirement for passive components. It consist of nine bi-directional switches arranged in matrix manner such that any input phase can be directly connected to any output phase. In most of the cases a three input three output converter will consist of bidirectional switches arranged in 3 row and 3 column manner resembles to a matrix of nine bi-directional switches, henceforth the term Indirect Matrix Converter. The method of switching off and on the bidirectional switch prepared the variable frequency and amplitude signals at the production of the matrix converter. Benefit of matrix converters, they are not used regularly in most of the industries. There are some reasons for the choice of conservative AC-DC-AC inverter above the matrix converter. Even though the matrix converter topology was started in 1970 breakthrough in the field of the matrix converter happened in last decade.

The number of the semiconductor switches in a matrix converter is greater than the number used in a DC-link converter. Therefore, the cost of implementation of a matrix converter is larger than a conventional dc-link converter of the same ratings. Finally, the amplitude of the output voltages generated by a matrix converter is narrow to 0.866 of the input voltage amplitude for the most standard modulation methods. Then, electrical motors or any additional typical device coupled as load to a matrix converter do not operate at their insignificant rated voltage. Even though Matrix converter has some disadvantages its very attractive for some application.

Firstly, there are applications where energy storage components like capacitors and inductors are to be evaded. For example, the huge electrolytic capacitors of a dc-link converter are one of the components that falls the dependability of the converter. Furthermore, the cost of power semiconductors stays to fall and around is no evidence to recommend that this trend will modification for the future. On the other pointer, the real cost of energy storage components is not dropping. For this reason, matrix converters will develop gradually more cost inexpensive. Thirdly, a matrix converter is a very attractive solution when redevelopment is required. The bidirectional power flow ability and input displacement factor control of matrix converters make them an ideal solution for similar application. Finally, there are applications where the converter dimension, weightiness and act is of major concern. The privation of large energy storing components and the integration of semiconductors in power modules specifically

designed for Indirect Matrix converters mean that large power density factors are achievable employing matrix converter.

## III. PREDICTIVE CURRENT CONTROL

Predictive control algorithm uses the finite number of valid switching states of the power converter. The proposed scheme maintains the predictive values closed to their respective references at the end of the sampling instant and maintain positive DC-link voltage between the rectifier and inverter stages which eliminates the extra usage of the large energy storage devices. Hence reduces the size and increase the life span of the converter. Predictive control algorithm with conventional weighting factor and proposed weighting factor optimization methods in order to reduce the torque ripple and flux control of the induction motor fed by an indirect matrix converter. The system behavior is highly changeable with the values of the weighting factor in the cost function. So, this method is highlighted with an imposed optimized weighting factor calculation method to reduce the torque ripple of the induction motor corresponding to the conventional predictive control scheme. Finally, the proposed weighting factor optimization method used in the cost function of the predictive control algorithm significantly improves the torque ripple of induction motor with potential control. Predictive controller satisfies all the aforementioned constraints by using the following five steps.

**Step 1:** Supply voltage  $k_s$ , input voltage  $k_i V$ , stator current  $k_o I$  and speed  $\omega_k$  of the induction motor are measured in the  $k$  the sampling instant.

**Step 2:** PI controller is used to set nominal torque  $\text{nom } T$  from the error signal between the measured and reference speeds of the induction motor where reference speed  $\text{ref } \omega$  is known value.

**Step 3:** Stator reference flux  $\text{ref } \psi$  is a given value and a flux estimator has been used to estimate the stator and rotor flux.

**Step 4:** For each valid switching states of indirect matrix converter, values of torque  $(k+1) T$  and stator flux  $\psi$  are predicted in the next sampling period  $(k+1)$ .

**Step 5:** All the predictive values are compared with their respective references and determine the cost functions for all possible switching states based on conventional weighting factor and with imposed optimized weighting factor. The switching state corresponds to the minimum cost function is selected in the next sampling time period to actuate the converter. Reduce the torque ripple corresponding to

conventional weighting factor based predictive control algorithm flow chart showing in Fig. 1

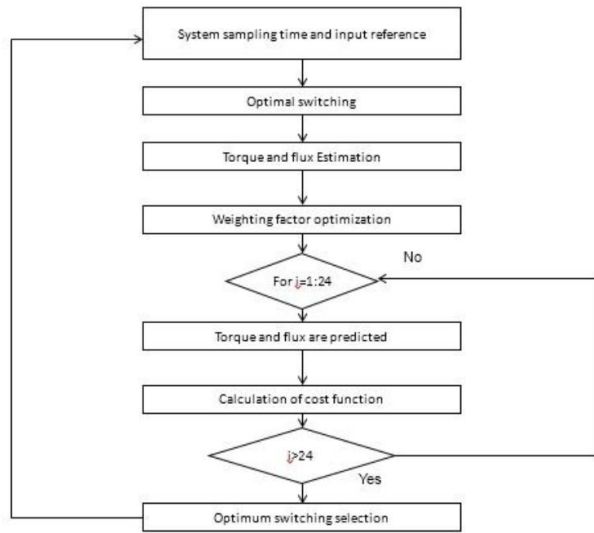

Fig 1 : Flow Chart for Predictive Current Control

Application of predictive control in indirect matrix converters. The switching state is selected by minimizing a quality function that considers the instantaneous reactive power in the input, the current error in the output, and the generation of a positive voltage in the dc link. Feasibility, implementation details, and advantages and disadvantages are also discussed. Due to the limited capacity of the controller, the use of a prediction horizon of one sample time will be depend upon a design criterion.

IV. PROPOSED TOPOLOGY

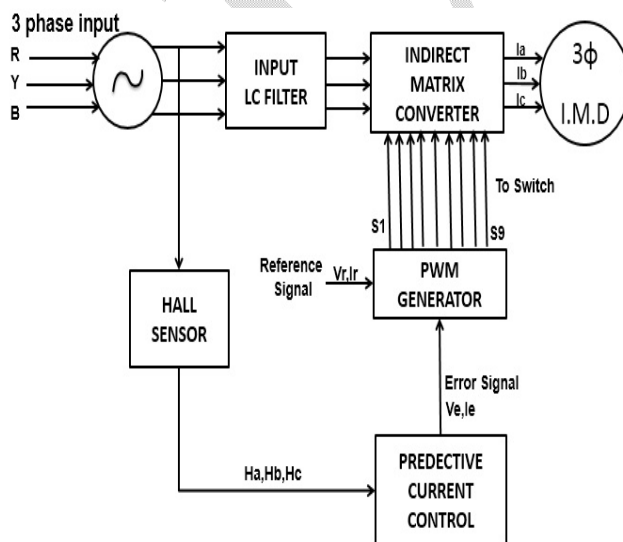

Fig 2: Block diagram of Proposed Method

To overcome demerits and to VSI and CSI enhance the power factor of induction motor, in the following this proposed method illustrates how the PCC can be applied to an IMC and how both source and load currents waveforms can be directly controlled. An optimization algorithm based Predictive Current Controller (PCC) is implemented which replaces the conventional VSI method with indirect matrix converter and how the source and load currents waveforms can be directly controlled. This method uses the commutation state of the converter in the subsequent sampling time according to an optimization algorithm given by a simple cost functional and the discrete system model. The aim of the proposed method is regulation of output current according to an arbitrary reference and also to have a good tracking of the source current to its reference which is imposed to have a sinusoidal waveform with low distortion. The proposed work were simulated in the MATLAB Simulink platform.

V. SIMULATION MODEL

The proposed control concept is verified through modelling circuit using predictive current controller in MATLAB/Simulink (MLS).The top level main model of a three phase matrix converter fed induction motor and power circuit of three phase matrix converter in MLS are shown Fig 2.

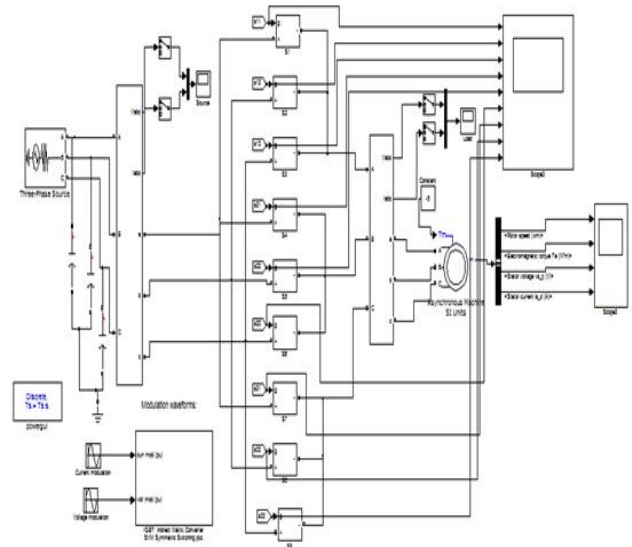

Fig 3. Simulation model of three phase matrix converter

In SPWM model as shown in Fig 3 The reference signal is compared with the carrier signal to produce the required SV-PWM output. The assessment is made using “Relational Operator” block in predictive current controller. The carrier signal is generated by using “Repeating Sequence” block that produce triangular wave signal.

In the result of rotor speed, Electromagnetic Torque, Stator Current, Stator Voltage we can check the performance of the Induction motor in the industrial applications.

The table I represents the block parameters of the proposed system. All these parameter are taking as a input of the matrix converter that is the input voltage 440V, and the carrier signal frequency is 20 KHz and reference signal frequency of the converter is 50 Hz, Resistor value is 100 ohm, Inductor values is 3 mH and LC filter can be used to remove a source current ripple content and the LC filter values are 0.1 mH, 6.8  $\mu$ F.

Table I Block Parameters of Matrix Converter

COMPONENT	VALUE
INPUT SOURCE (AC)	440 V
FREQUENCY OF CARRIER SIGNAL, FC	20 KHZ
FREQUENCY OF REFERENCE SIGNAL, FR	50 HZ
DUTY CYCLE (D)	0.3,0.7
OUTPUT RESISTOR, R OUTPUT INDUCTOR, L	100 $\Omega$ 3 mH
LC FILTER	L= 0.1 mH C= 6.8 $\mu$ F

In Fig 3 has a 9 switches and they are conducted in the way of bidirectional and they are arranged in the form of 3x3 matrix. All switches are conducting with their pairs (1-3),(2-4),(3-5),(4-6),(5-7),(6-8),(7-9),(8-1),(9-2).These switches are controlled with the help of SVPWM Controller.

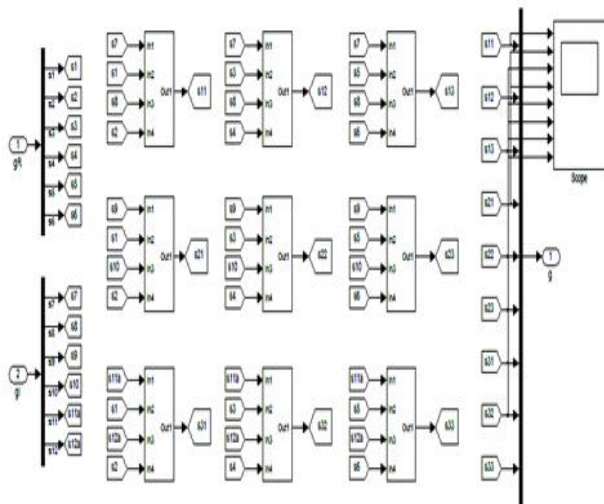

Fig 4: Switching Pattern

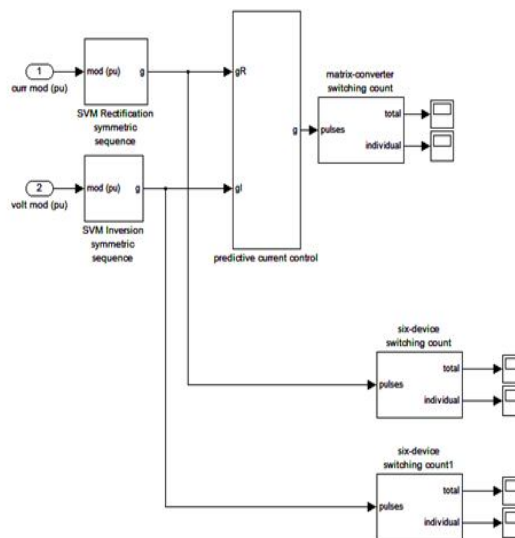

Fig 5: SVPWM Block

SV-PWM is in fact a modulation algorithm which translates phase voltage (phase to neutral) references, coming from the controller, into modulation times/duty-cycles to be applied to the PWM peripheral.

## VI. RESULTS AND DISCUSSIONS

The speed response of indirect matrix converter fed induction motor is shown in Figure.5. The speed of the motor is linearly varied at attain a reference value at 0.02ms as 700rpm. After that the speed should be constant. There is no dip and rise in the speed.

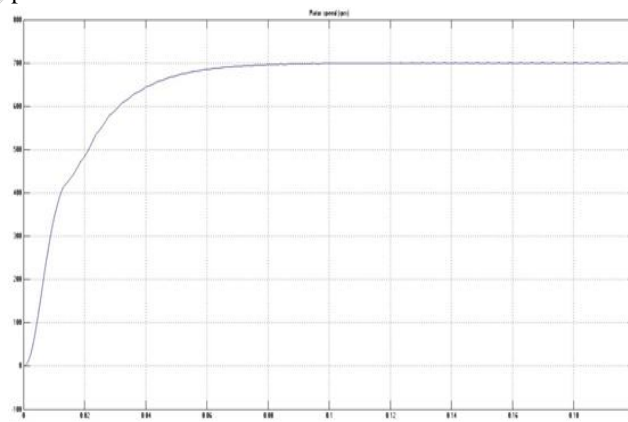

Fig 6: Speed Response

The electromagnetic torque waveform is shown in Figure.6 due to the harmonics in the stator current, the generated electromagnetic torque contains ripple in its waveform. The starting torque of the motor is high. After attaining the rated speed, the torque should attain a nominal value.



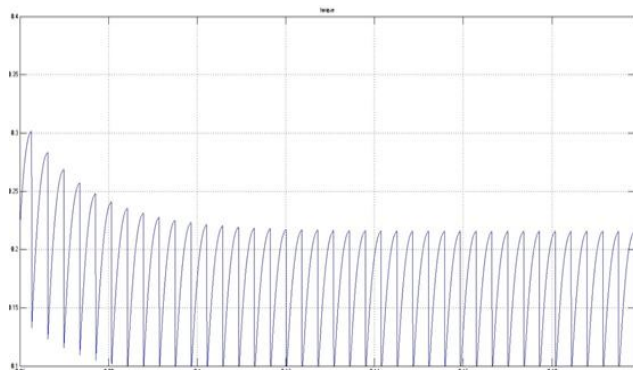

Fig. 7: Electromagnetic Torque

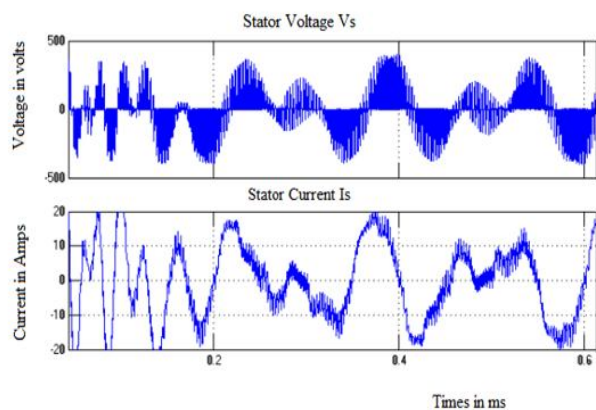

Fig 8: Stator voltage and current waveform

The stator voltage and stator current waveform is shown in Figure.7 the motor is powered by indirect matrix converter which is variable frequency operated drive. So the stator voltage and current waveform contains periodic dip and rise. The waveform is look like a pulse width modulated waveform due to the switching of the converter. Because of this switching, the generated torque contains significant amount of ripple increase the efficiency of the motor.

## VII. CONCLUSION

In this paper, the new topology of Voltage Source Inverter (VSI) replaced by the indirect matrix converter. Predictive controller algorithm is utilized to control the source and load current waveforms directly. Indirect matrix converter uses in complex PWM schemes to achieve the goal of unity power factor and sinusoidal output current. Hence the performance of the induction motor can be improved. The proposed method is analyzed using MATLAB/SIMULINK software. From the simulation results it is clearly understand that the smooth speed control is obtained during acceleration and deceleration by controlling the voltage at dc link. Simulated results are presented to demonstrate an improved performance of induction motor.

## References

- [1] T. Wijekoon, C. Klumpner, and P. Wheeler, "Implementation of a hybrid AC/AC direct power converter with unity voltage transfer ratio," in *Proc. 21st Annu. IEEE APEC*, 2006, p. 7.
- [2] J. Kolar, T. Friedli, F. Krismer, and S. Round, "The essence of three-phase AC/AC converter systems," in *Proc. 13th EPE-PEMC*, 2008, pp. 27–42.
- [3] P. Correa, J. Rodriguez, M. Rivera, J. Espinoza, and J. Kolar, "Predictive control of an indirect matrix converter," *IEEE Trans. Ind. Electron.*, vol. 56, no. 6, pp. 1847–1853, Jun. 2009.
- [4] P. Zanchetta, P. Wheeler, J. Clare, M. Bland, L. Empringham, and D. Katsis, "Control design of a three-phase matrix-converter-based ac/mobile utility power supply," *IEEE Trans. Ind. Electron.*, vol. 55, no. 1, pp. 209–217, Jan. 2008.
- [5] S. Lopez Arevalo, P. Zanchetta, P. Wheeler, A. Trentin, and L. Empringham, "Control and implementation of a matrix-converter based ac ground power-supply unit for aircraft servicing," *IEEE Trans. Ind. Electron.*, vol. 57, no. 6, pp. 2076–2084, Jun. 2010.
- [6] E. Yamamoto, T. Kume, H. Hara, T. Uchino, J. Kang, and H. Krug, "Development of matrix converter and its applications in industry," in *Proc. 35th IEEE IECON*, Porto, Portugal, 2009, pp. 4–12.
- [7] X. Lu, K. Sun, G. Li, and L. Huang, "Analysis and control of input power factor in indirect matrix converter," in *Proc. 35th IEEE IECON*, 2009, pp. 207–212.
- [8] M. Jussila and H. Tuusa, "Comparison of simple control strategies of space-vector modulated indirect matrix converter under distorted supply voltage," *IEEE Trans. Power Electron.*, vol. 22, no. 1, pp. 139–148, Jan. 2007.
- [9] R. Pena, R. Cardenas, E. Reyes, J. Clare, and P. Wheeler, "A topology for multiple generation system with doubly fed induction machines and indirect matrix converter," *IEEE Trans. Ind. Electron.*, vol. 56, no. 10, pp. 4181–4193, Oct. 2009.
- [10] M. Y. Lee, P. Wheeler, and C. Klumpner, "Space-vector modulated multilevel matrix converter," *IEEE Trans. Ind. Electron.*, vol. 57, no. 10, pp. 3385–3394, Oct. 2010.
- [11] R. Cardenas-Dobson, R. Pena, P. Wheeler, and J. Clare, "Experimental validation of a space vector modulation algorithm for four-leg matrix converters," *IEEE Trans. Ind. Electron.*, vol. 58, no. 4, pp. 1282–1293, Apr. 2011.
- [12] T. Friedli and J. Kolar, "Comprehensive comparison of three-phase AC/AC matrix converter and voltage DC-link back-to-back converter systems," in *Proc. IPEC*, 2010, pp. 2789–2798.
- [13] J. Kolar, F. Schafmeister, S. Round, and H. Ertl, "Novel three-phase AC/AC sparse matrix converters," *IEEE Trans. Power Electron.*, vol. 22, no. 5, pp. 1649–1661, Sep. 2007.
- [14] S. Kouro, P. Cortes, R. Vargas, U. Ammann, and J. Rodriguez, "Model predictive control, a simple and powerful method to control power converters," *IEEE Trans. Ind. Electron.*, vol. 56, no. 6, pp. 1826–1838, Jun. 2009.
- [15] J. Rodriguez, J. Pontt, C. A. Silva, P. Correa, P. Lezana, P. Cortes, and U. Ammann, "Predictive current control of a voltage source inverter," *IEEE Trans. Ind. Electron.*, vol. 54, no. 1, pp. 495–503, Feb. 2007.
- [16] P. Correa, J. Rodriguez, I. Lizama, and D. Andler, "A predictive control scheme for current-source rectifiers," *IEEE Trans. Ind. Electron.*, vol. 56, no. 5, pp. 1813–1815, May 2009.

- [17] P. Cortes, G. Ortiz, J. Yuz, J. Rodriguez, S. Vazquez, and L. Franquelo, "Model predictive control of an inverter with output LC filter for UPS applications," *IEEE Trans. Ind. Electron.*, vol. 56, no. 6, pp. 1875–1883, Jun. 2009.
- [18] H. Miranda, P. Cortes, J. Yuz, and J. Rodriguez, "Predictive torque control of induction machines based on state-space models," *IEEE Trans. Ind. Electron.*, vol. 56, no. 6, pp. 1916–1924, Jun. 2009.
- [19] M. Preindl, E. Schaltz, and P. Thøgersen, "Switching frequency reduction using model predictive direct current control for high power voltage source inverters," *IEEE Trans. Ind. Electron.*, vol. 58, no. 7, pp. 2826–2835, Jul. 2011.
- [20] S. Muller, U. Ammann, and S. Rees, "New time-discrete modulation scheme for matrix converters," *IEEE Trans. Ind. Electron.*, vol. 52, no. 6, pp. 1607–1615, Dec. 2005.
- [21] R. Vargas, J. Rodriguez, U. Ammann, and P. Wheeler, "Predictive current control of an induction machine fed by a matrix converter with reactive power control," *IEEE Trans. Ind. Electron.*, vol. 55, no. 12, pp. 4362–4371, Dec. 2008.
- [22] P. Cortes, M. Kazmierkowski, R. Kennel, D. Quevedo, and J. Rodriguez, "Predictive control in power electronics and drives," *IEEE Trans. Ind. Electron.*, vol. 55, no. 12, pp. 4312–4324, Dec. 2008.
- [23] P. Cortes, J. Rodriguez, D. Quevedo, and C. Silva, "Predictive current control strategy with imposed load current spectrum," *IEEE Trans. Power Electron.*, vol. 23, no. 2, pp. 612–618, Mar. 2008.
- [24] J. Rodriguez, J. Kolar, J. Espinoza, M. Rivera, and C. Rojas, "Predictive current control with reactive power minimization in an indirect matrix converter," in *Proc. IEEE ICIT*, Mar. 2010, pp. 1839–1844.
- [25] M. Rivera, P. Correa, J. Rodriguez, I. Lizama, and J. Espinoza, "Predictive control of the indirect matrix converter with active damping," in *Proc. IEEE 6th IPEDC*, May 2009, pp. 1738–1744.